

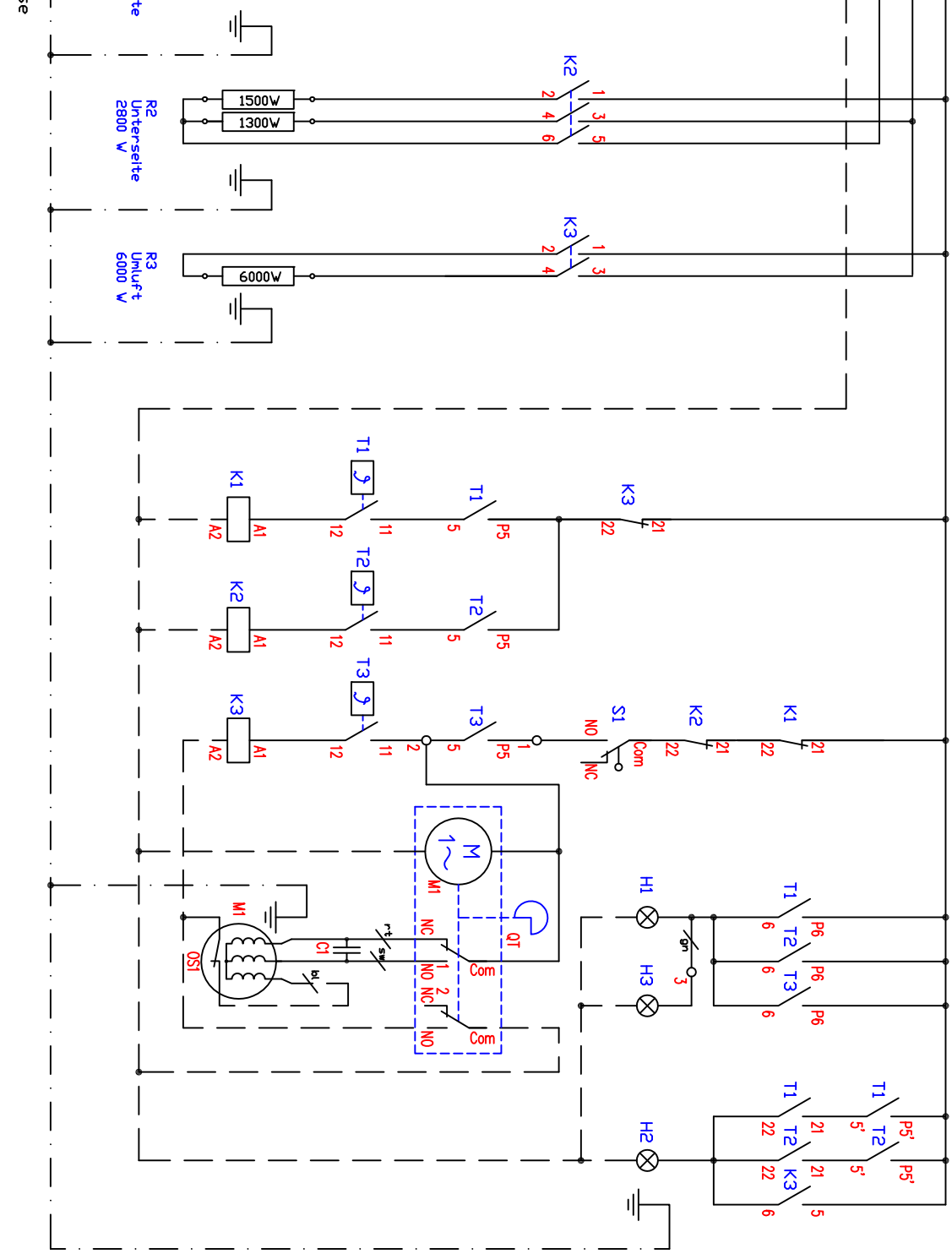

Festanschluss 16A
optional: CEE16A
400V/3~/N/PE

PE
gn/ge PE
Kabel 1 Gehäuse



Kabel 1 - SHF 5G2,5 gmm		01300011	M1 - Umluftmotor	100327	Schaltplan Umluft- Einbaubackofen BEB(Q)U2/1 5,6kW/6,0kW	 Berner-Kochsysteme GmbH & Co. KG Sudetenstraße 5 D-87471 Durach Tel:+49(0)831/697247-0, Fax:-15 berner@induktion.de www.induktion.de	<table border="1"> <tr> <th colspan="2">Änderung</th> </tr> <tr> <td>a</td> <td></td> </tr> <tr> <td>b</td> <td></td> </tr> <tr> <td>c</td> <td></td> </tr> <tr> <th colspan="2">Version</th> </tr> <tr> <td>1.7</td> <td></td> </tr> </table>	Änderung		a		b		c		Version		1.7	
Änderung																			
a																			
b																			
c																			
Version																			
1.7																			
			C1 - Kondensator 2,5µF 450V	100328															
			QT - Zeitschalter 'Drehrichtung'	100326															
			K1-K3 - Schütz 20A DILEM-01	800297															
			H1 - Betrieb 'Ein' gr/wh 230V	800201															
SI - Türkontaktschalter		200353	H2 - Heizlampe gelb 230V	800206															
T1,T2 - Thermostat 77-300°C		700101	H3 - Innenbeleuchtung 230V	800230															
T3 - Thermostat Umluft		500300	R1,R2 - Heizung 400V/2,8kW	500606															
			R3 - Heizung Umluft	500614															

Schaltplan		Bla tt	1/1	Datum	18.06.18	Zeichner	Hinkel	
BEB-8/1							Schaltplan	